

Copia no Controlada

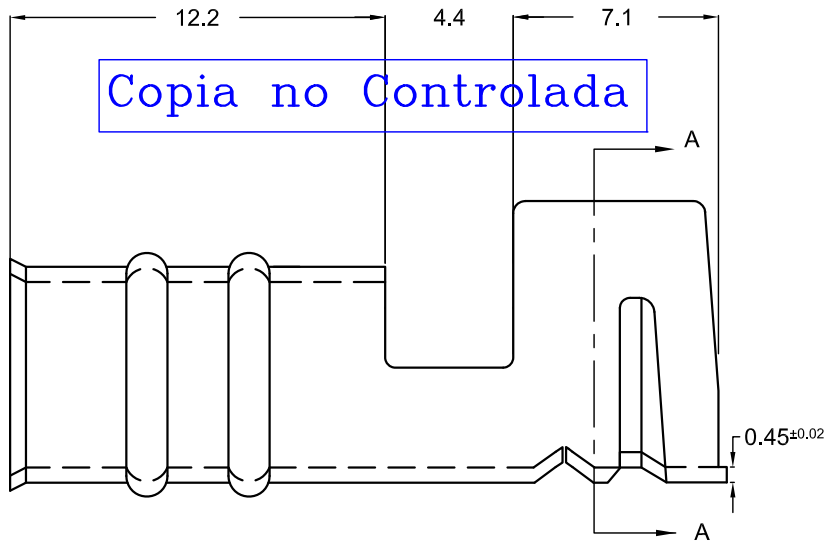

SECC. A-A

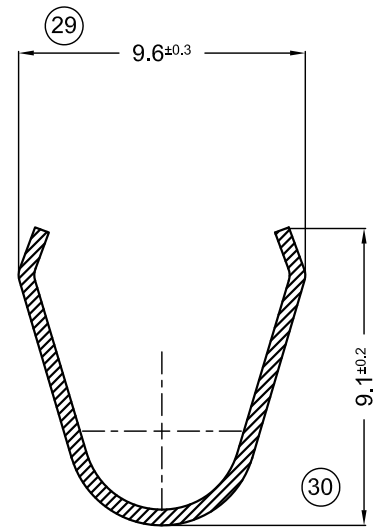

ESCALA:4:1

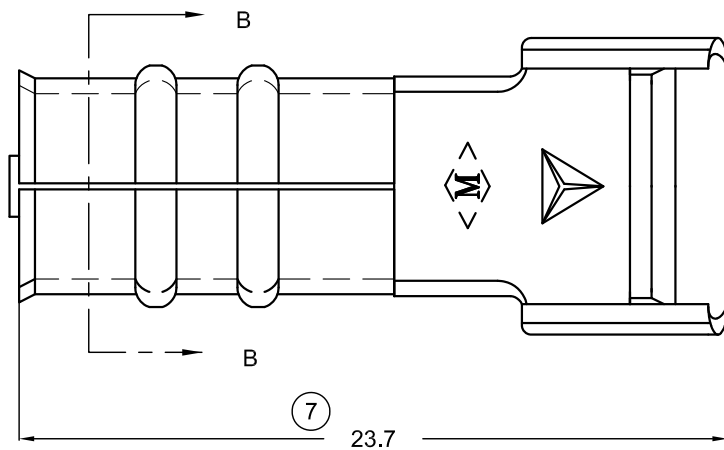

SECC. B-B

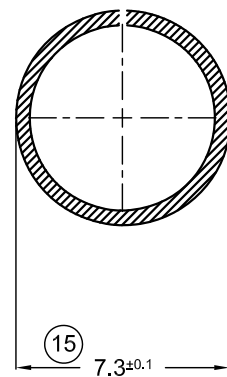

Plano sujeto a modificaciones sin previo aviso

PARA PRESENTACIÓN "SUELTOS", CÓDIGO SIN "C" FINAL

Tolerancias no especificadas ± 0.2

| CÓDIGO de PIEZA | MATERIAL | Ø DE CABLE | TERMINACIÓN | PIEZAS x CARRETEL | CANTIDAD x ENVASE |
|-----------------|---------------|------------|-------------|-------------------|-------------------|
| 1.08.1480C | LATÓN CuZn 30 | 7mm | NATURAL | 2500 | 1000 |
| | | | | | |
| | | | | | |
| | | | | | |

DIRECCIÓN DE SALIDA EN CARRETEL

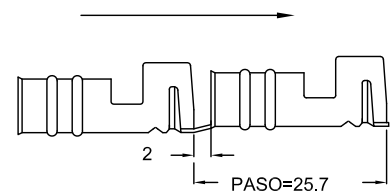

ESCALA: 1=1

| | |
|---------|---|
| N° | REVISIÓN/FECHA |
| 00 | 1º EDICIÓN - 23/05/90 |
| 01 | CAMBIO FORMATO de HOJA A 4 - 10/03/2022 |
| | |
| | |
| DIBUJÓ: | R.ALVAREZ 21/05/90 |
| REVISÓ: | D. DACAL 23/05/90 |

METALGRAB S.R.L



TERMINAL PARA BUJIA AUTOMOTOR

PLANO CLIENTE: 1480